



**Motortech**  
Supplying Tomorrows Technology Today

**Motor Serv Ltd**  
Units 1 & 2 Arden Park  
Old Wolverton Rd  
Old Wolverton  
Milton Keynes  
MK12 5RH

07726 361374    [ian@motorserv.co.uk](mailto:ian@motorserv.co.uk)

**GEA**

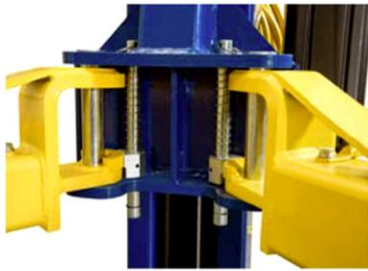

- 12,000-pound lifting capacity
- Open-top eliminates overhead obstruction
- Wide or narrow configuration
- Single-piece columns
- Single point safety release
- Drop-end arms provide a lower pad height
- Triple-telescoping arms provide increased range for lifting point access
- Dual hydraulic "Direct-Drive" Cylinders
- Automatic arm restraints
- Oversize 53" tall carriage for superior strength and durability
- Heavy-duty dual 1/2" equalizer cables with oversize cable sheaves
- Truck and van adapters as standard
- ETL Approved (Pending)
- Electric/hydraulic power system
- Large, 25" x 22" steel base plates
- Self-lubricating dura-glide polyethylene bearing system
- Safety locks in each column spaced every 3-inches
- 5 year structure warranty



**Motortech**  
Supplying Tomorrows Technology Today

**Motor Serv Ltd**  
Units 1 & 2 Arden Park  
Old Wolverton Rd  
Old Wolverton  
Milton Keynes  
MK12 5RH

07726 361374    ian@motorserv.co.uk

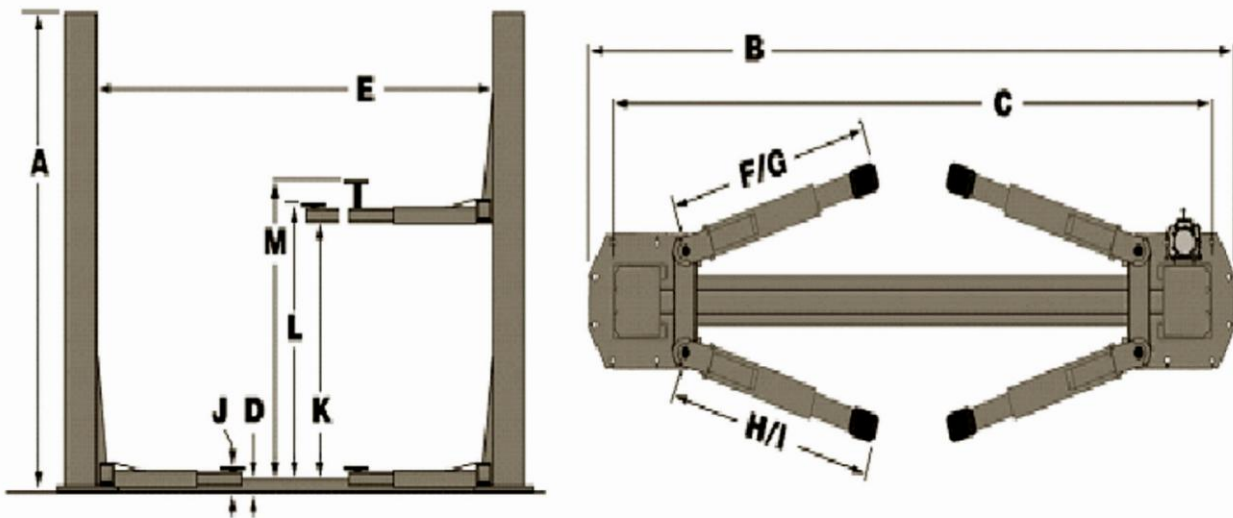

MODEL	XPR-12FD	XPR-12FD-LWB
Lifting Capacity*	12,000 Lbs. / 5443 Kg.	12,000 Lbs. / 5443 Kg.
*Max Capacity / Front Axle	6,000 lbs. / 2722 Kg.	6,000 lbs. / 2722 Kg.
*Max Capacity / Rear Axle	6,000 lbs. / 2722 Kg.	6,000 lbs. / 2722 Kg.
A - Height Overall:	144" / 3403 mm.	144" / 3403 mm.
B - Width Overall (Outside of Base Plate):	155" / 3937 mm.	155" / 3937 mm.
C - Width (Outside of Columns):	146" / 3708 mm.	146" / 3708 mm.
D - Cover Height:	2" / 51 mm.	2" / 51 mm.
E - Inside Columns:	118" / 2997 mm.	118" / 2997 mm.
F - Reach (Front Arm Min.):	39" / 991 mm.	35-1/2" / 902 mm.
G - Reach (Front Arm Max.):	59" / 1499 mm.	71-1/2" / 1816 mm.
H - Reach (Rear Arm Min.):	39" / 991 mm.	35-1/2" / 902 mm.
I - Reach (Rear Arm Max.):	59" / 1499 mm.	71-1/2" / 1816 mm.
J - Min. Pad Height:	5" / 127 mm.	5" / 127 mm.
K - Rise:	69" / 1753 mm.	69" / 1753 mm.
L - Max Lift Height (Pad Only):	74" / 1880 mm.	74" / 1880 mm.
M - Max Lift Height (6" Adapter):	80" / 2032 mm.	80" / 2032 mm.
N - Drive-Thru Clearance:	103" / 2616 mm.	103" / 2616 mm.
Motor (*)	220 VAC / 60 Hz. 1Ph.	220 VAC / 60 Hz. 1Ph.
Time of full Rise:	55 Seconds	55 Seconds
Max Load Per Arm:	3,000Lbs. / 1361 Kg.	3,000Lbs. / 1361 Kg.

\* Special Voltages Available Upon Request.

The design, material and specifications are subject to change without notice.

